

Surname	Centre Number	Candidate Number
Other Names		0



GCSE

4370/03



S15-4370-03

**MATHEMATICS – LINEAR
PAPER 1
FOUNDATION TIER**

A.M. THURSDAY, 21 May 2015

1 hour 45 minutes

**CALCULATORS ARE
NOT TO BE USED
FOR THIS PAPER**

ADDITIONAL MATERIALS

A ruler, a protractor and a pair of compasses may be required.

INSTRUCTIONS TO CANDIDATES

Use black ink or black ball-point pen. Do not use gel pen or correction fluid.

Write your name, centre number and candidate number in the spaces at the top of this page.

Answer **all** the questions in the spaces provided.

If you run out of space, use the continuation page at the back of the booklet, taking care to number the question(s) correctly.

Take π as 3.14.

INFORMATION FOR CANDIDATES

You should give details of your method of solution when appropriate.

Unless stated, diagrams are not drawn to scale.

Scale drawing solutions will not be acceptable where you are asked to calculate.

The number of marks is given in brackets at the end of each question or part-question.

You are reminded that assessment will take into account the quality of written communication (including mathematical communication) used in your answer to question 11.

For Examiner's use only		
Question	Maximum Mark	Mark Awarded
1.	11	
2.	8	
3.	4	
4.	4	
5.	8	
6.	6	
7.	3	
8.	4	
9.	3	
10.	4	
11.	8	
12.	6	
13.	5	
14.	5	
15.	5	
16.	6	
17.	4	
18.	3	
19.	3	
Total	100	



MAY1543700301

Formula List

Area of trapezium = $\frac{1}{2}(a + b)h$

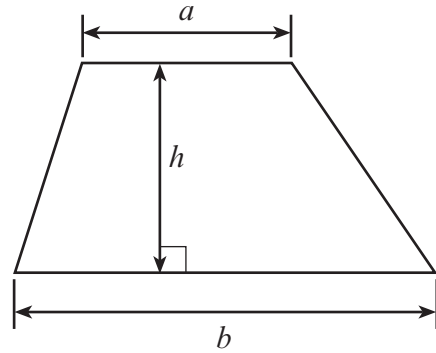

Volume of prism = area of cross-section \times length

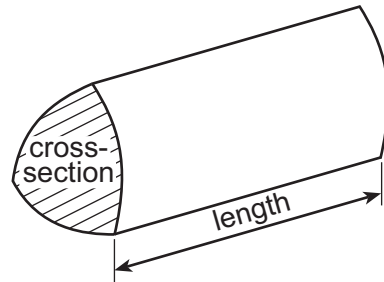

1. (a) (i) In a recent election, the winning candidate had twenty-six thousand and forty-three votes. Write down this number of votes in figures. [1]
-
- (ii) The candidate who came second received 20015 votes. Write down this number of votes in words. [1]
-
- (iii) By how many votes did the winning candidate beat the second-placed candidate? Write your answer in figures. [1]
-
-
-
- (b) Using only the numbers in the following list,
38 49 23 12 47 37 40
write down
- (i) two numbers that add up to 75, [1]
-
- (ii) two numbers which differ by 17, [1]
-
- (iii) a square number. [1]
-
- (c) Write 9758 correct to the nearest thousand. [1]
-
- (d) Write down all the factors of 21. [2]
-
- (e) Each of the digits 7, 9, 2 and 6 is used once to make a four-digit number.
- (i) What is the smallest number that can be made? [1]
-
- (ii) What is the largest odd number that can be made? [1]
-



2. (a) Write down the next term in each of the following sequences. [2]

(i) 45, 34, 23, 12,

(ii) 64, 16, 4, 1,

.....
.....

(b) What is the value of the 6 in the number 95612? [1]

.....

(c) Write $\frac{33}{50}$ as a decimal

Write 67% as a decimal

Write 67%, 0.68 and $\frac{33}{50}$ in ascending order. [3]

.....

(d) Showing all your working, find an estimate for the value of 5.17×9.8 . [2]

.....

.....

.....



3. The formula for finding the value of any term in a sequence is

$$\text{value} = 6 \times \text{the term number} - 5$$

- (a) Find the **value** when the **term number** is 7.

[2]

.....

.....

.....

.....

- (b) Find the **term number** when the **value** is 67.

[2]

.....

.....

.....

.....



4. (a) A box contains the following 10 cards.

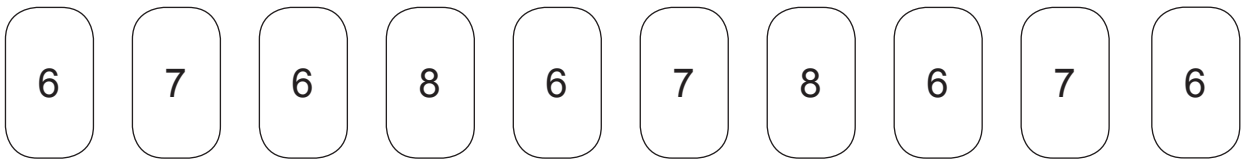

One card is chosen at random from the box.

On the probability scale shown below, mark the points A, B and C where:

A is the probability that the chosen card has the number 6 on it,

B is the probability that the chosen card has a number **less than 8** on it,

C is the probability that the chosen card has a number **more than 5** on it.

[3]

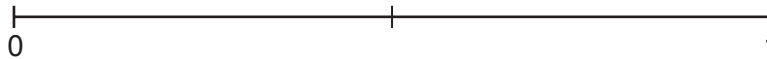

- (b) Choose the best word from those given below to describe the chance that the chosen card has a 7 on it. [1]

impossible

unlikely

even chance

likely

certain

.....



5. (a) Simplify $4a + 2a - a$. [1]

.....

.....

(b) Use the formula $W = 7R - 3T$ to find the value of W when $R = 5$ and $T = 9$. [2]

.....

.....

.....

(c) The x and y values of the coordinates of the points (2, 6), (3, 9), (4, 12), (x, y) all follow the same rule. [2]
Write down the rule connecting x and y .

.....

.....

.....

(d) Solve

(i) $5x = 20$ [1]

.....

.....

.....

(ii) $y + 8 = 20$ [1]

.....

.....

.....

(iii) $9 - t = 7$ [1]

.....

.....

.....



6. An 8 cm by 3 cm rectangle is placed on top of two 6 cm by 3 cm rectangles to make the shape shown in the diagram.

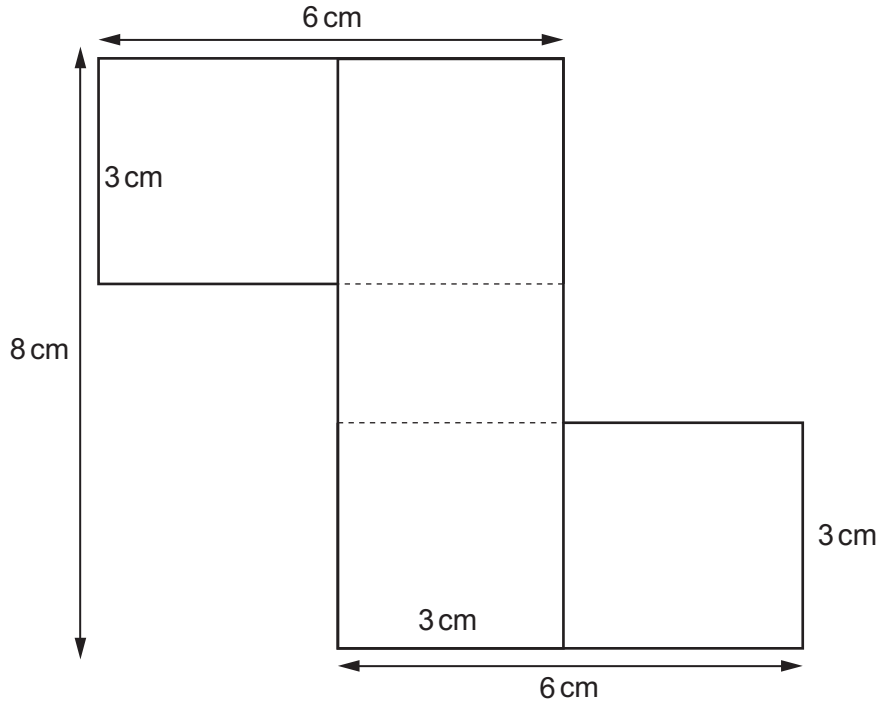

Diagram not drawn to scale

- (a) Calculate the perimeter of the shape.

[3]

.....

.....

.....

- (b) Calculate the area of the shape.
Write down the units of your answer.

[3]

.....

.....

.....

.....



7. On the squared paper below, plot the points $A(5, 2)$, $B(-1, -5)$ and $C(-4, 3)$.

[3]

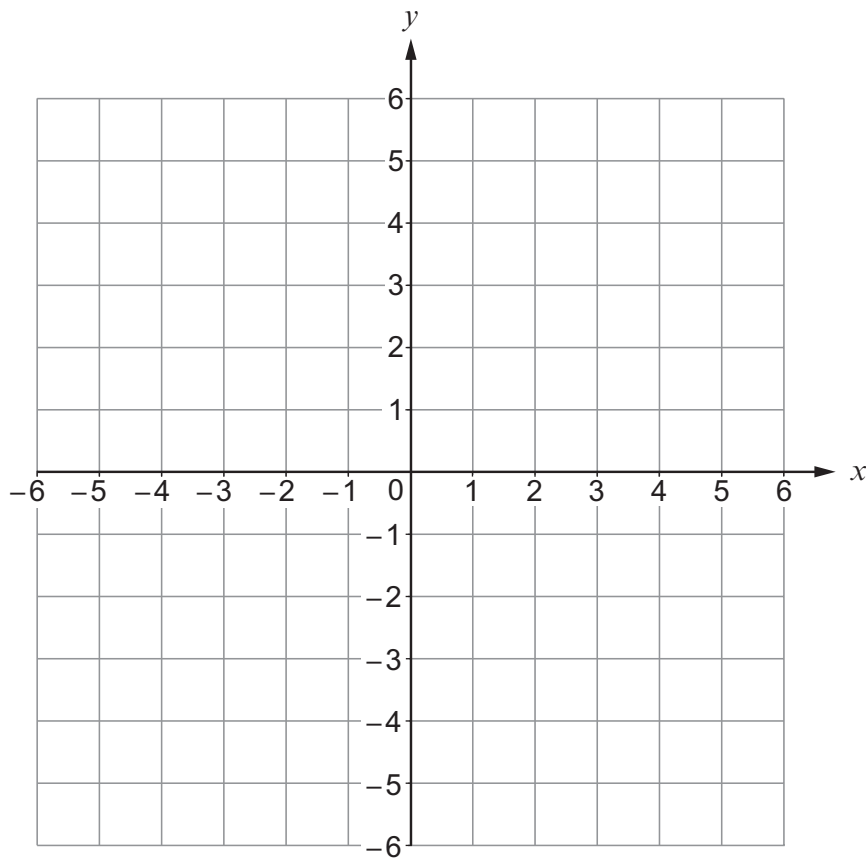

8. A surveyor has placed a pole at a point Q and another at R . The poles are 100 m apart.

He needs to position another pole at a point P such that:

- $\hat{PQR} = 44^\circ$
- P is at a distance of 80 metres from Q .

(a) Using a scale of 1 cm to represent 10 metres draw an accurate drawing of the position of the pole at P . [2]



(b) How far is the pole at P from R ? Give your answer in metres. [2]

.....

.....



9. Water is poured into an empty rectangular tank of length 15 cm, width 10 cm and height 12 cm until the tank is full. Calculate the volume, in litres, of the water in the tank. [3]

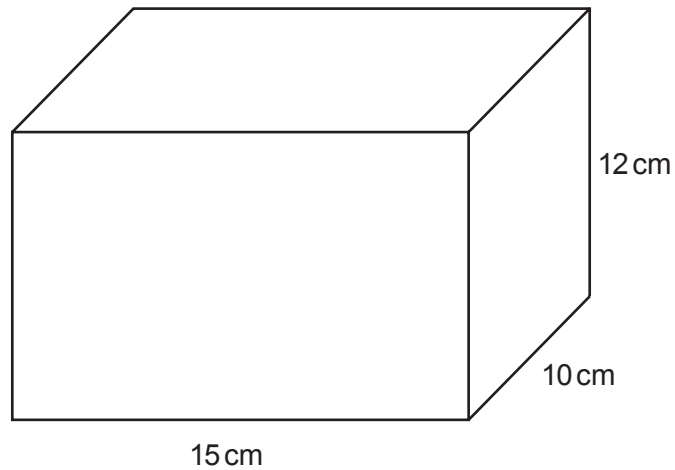

Diagram not drawn to scale

.....

.....

.....

.....

.....

Volume of water = litres



10. (a) Draw two more shapes so that the completed pattern has rotational symmetry of order 4 about O. [2]

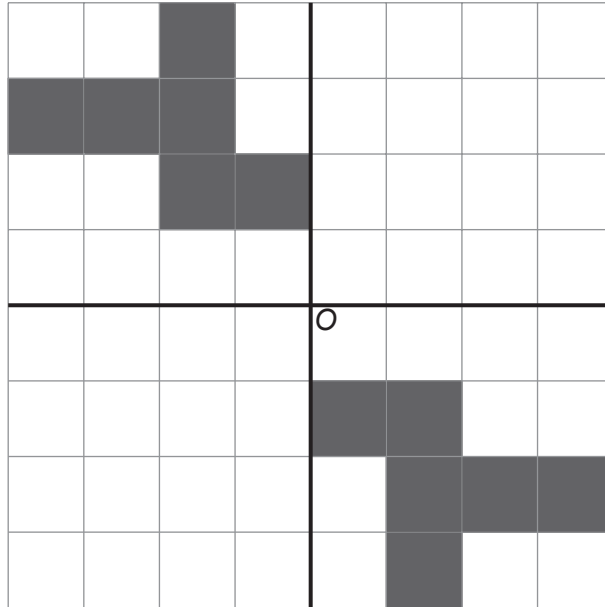

- (b) Draw all the lines of symmetry on the following diagram. [2]

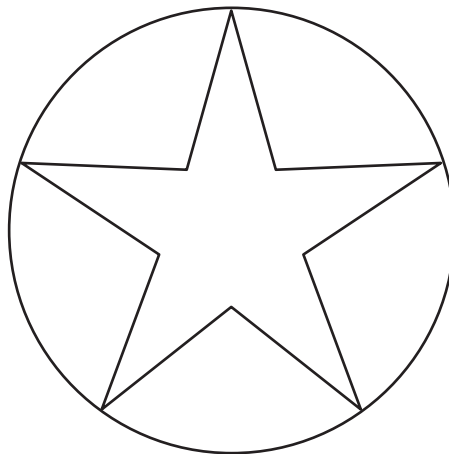

11. *You will be assessed on the quality of your written communication in this question.*

Tim owns a clothes shop.
He buys 60 shirts at £8 each.

The selling price of each shirt is worked out so that he makes a profit of 50% on each shirt.
He sells 15 shirts at this price.

After a few months Tim reduces the selling price of each shirt by £5.
He then sells the remaining shirts at this reduced selling price.

Has Tim made a profit or loss?
You must explain your answer clearly.

[8]

.....

.....

.....

.....

.....

.....

.....

.....

.....

.....

.....

.....

.....

.....

.....

.....

.....

.....

.....

.....

.....

.....



12. (a) Karen has 12 cards.
4 are yellow, 4 are red and 4 are blue.
The 4 yellow cards are numbered 1, 2, 3 and 4. Similarly, the 4 red cards and the 4 blue cards are numbered 1, 2, 3 and 4.
The 12 cards are all put in a bag and one card is drawn out of the bag at random.
Write down all the possible outcomes. One has been done for you. [2]

Yellow, 1

.....

.....

.....

.....

.....

.....

(b) (i) In a game, a player selects a card at random from the bag.
The player wins a prize if the selected card is a red card with an even number on it.
What is the probability that the player wins a prize? [2]

.....

.....

.....

(ii) One day 120 people play this game once. How many people would you expect to win a prize? [2]

.....

.....

.....



13. (a) In the diagram, PS , QT and RU are straight lines. Find the size of angle x .

[2]

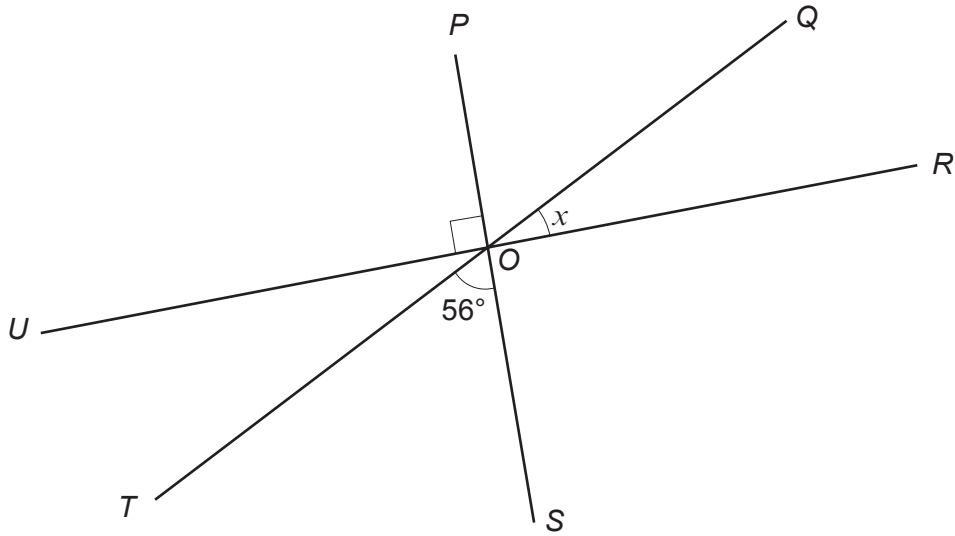

Diagram not drawn to scale

.....

.....

$x = \dots\dots\dots^\circ$

- (b) $ABCD$ is a rhombus. Find the size of angle y .

[3]

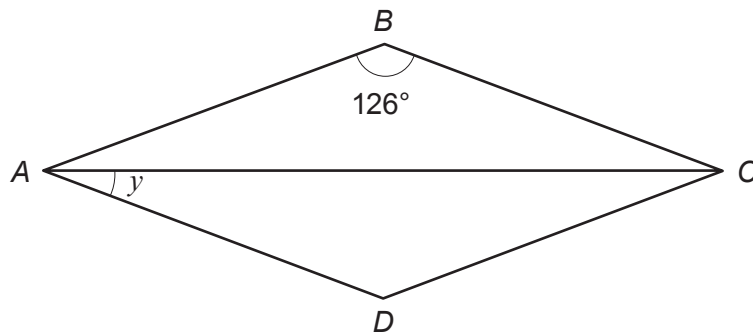

Diagram not drawn to scale

.....

.....

.....

.....

$y = \dots\dots\dots^\circ$



14. In a factory there are two machines.
Machine A makes plastic spoons and Machine B makes plastic forks.
Both machines work at a steady rate.

Machine A makes **180** plastic spoons per hour.



Machine B makes **240** plastic forks per hour.



Both machines start their production on a Monday morning at 9 a.m.
Both machines are stopped for maintenance after 450 spoons have been produced.
Calculate

- the time at which the machines were stopped for maintenance
- the number of forks produced between 9 a.m. and the time the machines were stopped for maintenance.

[5]

.....

.....

.....

.....

.....

.....

.....

.....

.....

.....

.....

.....

.....

.....

.....

.....

.....

.....

.....

.....

.....

.....

.....



Examiner
only

A large rectangular area with a solid top and bottom border and a dotted line border on the left and right sides, intended for writing.



15. The map below shows a route from Edinburgh to Dundee.

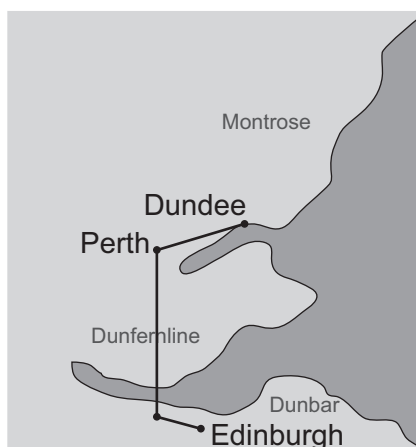

The route from Edinburgh to Dundee is approximately 4 cm on the map.
The actual journey is approximately 100 kilometres.

(a) Calculate the scale of the map, giving your answer in the form **1** : [2]

.....

.....

.....

.....

.....

.....

(b) The journey from Edinburgh to Dundee takes 2 hours 30 minutes by car.
Calculate the average speed of this journey.
Give your answer in kilometres per hour. [3]

.....

.....

.....

.....

.....

.....

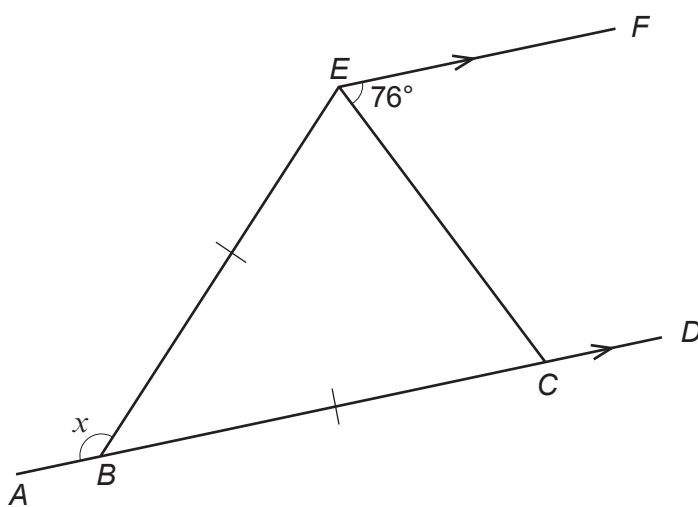

16.

*Diagram not drawn to scale*

$ABCD$ is a straight line.
 EF is parallel to AD .
 $BE = BC$.

Calculate the size of angle x .

You must give a reason for each step of your answer.

You must show all your working.

[6]

.....

.....

.....

.....

.....

.....

.....

.....

.....

.....

.....

.....

.....

.....

.....

.....

.....

.....

.....

.....

.....

.....

.....

.....

.....



17. (a) Rotate triangle *A* through 90° anticlockwise about the point $(2, -1)$. [2]

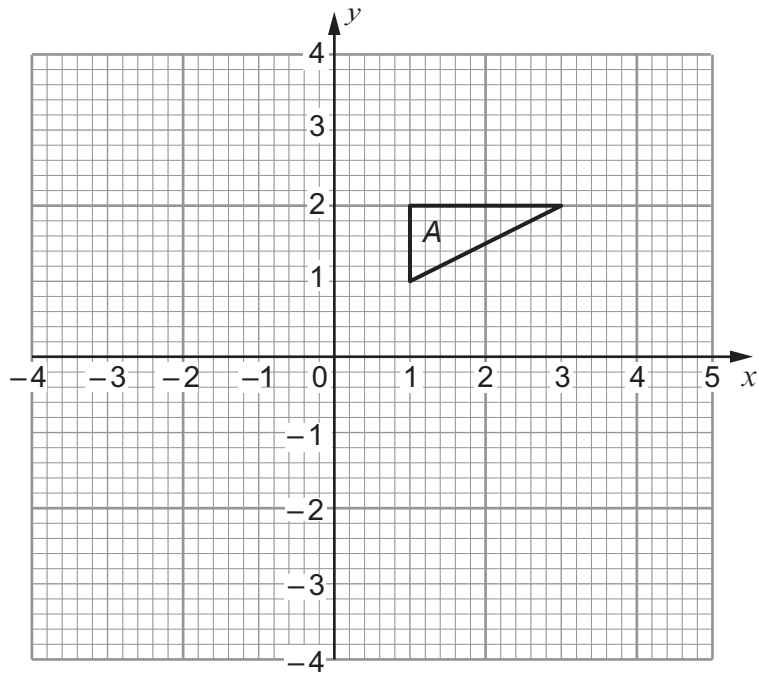

- (b) Using the point *B* as the centre, enlarge the quadrilateral by a scale factor of 2. [2]

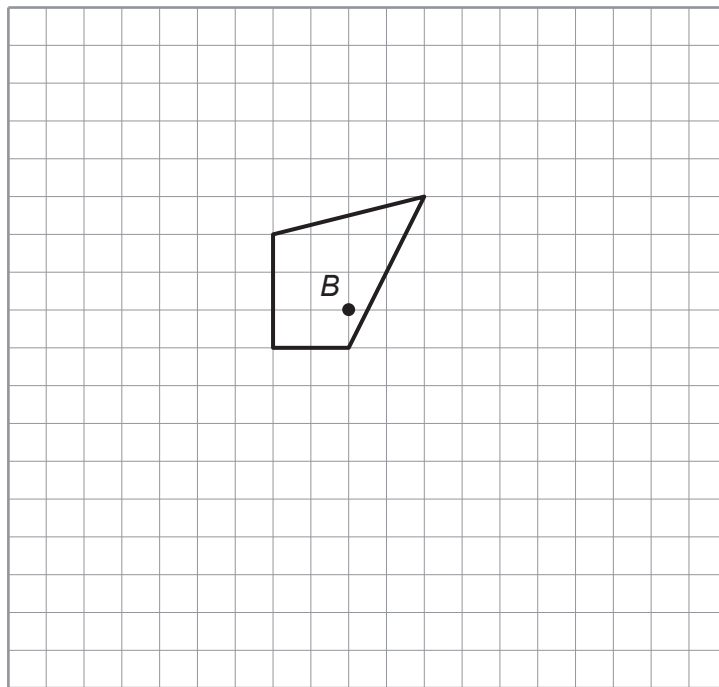

18. The diagram below shows part of a regular polygon.



Diagram not drawn to scale

How many sides does this regular polygon have altogether?

[3]

.....

.....

.....

.....

.....

.....

.....



19. A hollow cylinder is made with an internal radius of 4 cm and an internal height of 10 cm.

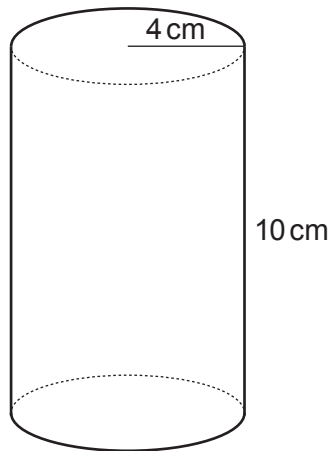

Diagram not drawn to scale

Carwyn says

'This cylinder holds approximately 5 litres of liquid.'

By estimating π as 3, show whether Carwyn is correct or not.

You must show your working and give a reason for your answer.

[3]

.....

.....

.....

.....

.....

.....

.....

.....

.....

.....

.....

.....

.....

.....

.....

.....

.....

.....

.....

.....

.....

.....

.....

END OF PAPER



BLANK PAGE

**PLEASE DO NOT WRITE
ON THIS PAGE**



